

W/ ANTI-GLARE LOUVER  
& CLEAR DIFFUSER  
配低眩光百葉及透明罩  
TVI-7301



W/ ANTI-GLARE OPAL DIFFUSER  
配奶白低眩光罩  
TVI-7302



W/ ASYMMETRIC REFLECTOR  
& CLEAR DIFFUSER  
配不對稱反射片及透明罩  
TVI-7303



## DIMENSION 尺寸

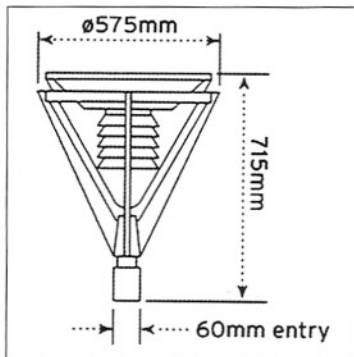

P.60

## PHOTOMETRIC DATA 配光曲線圖

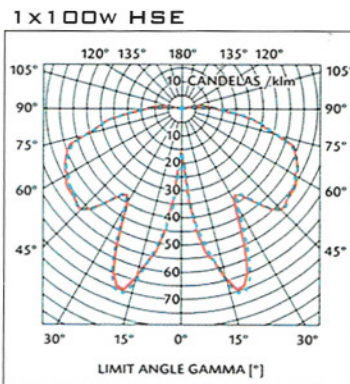

## APPLICATIONS

GENERAL AREA LIGHTINGS . PARKS / GARDENS .  
PARKING AREAS . PEDESTRIAN WAYS

## STRUCTURE

CORROSION RESISTANT DIE-CAST ALUMINIUM BODY COMPONENT.  
CORROSION RESISTANT EXTRUDED ALUMINIUM POLE.  
CLEAR / OPAL POLYCARBONATE DIFFUSER.  
STAINLESS STEEL SCREWS.  
SILVER ANODIZED ALUMINIUM LOUVER.  
WEATHER PROOF SILICONE GASKET.  
INTEGRAL CONTROL GEAR.  
CHROMATIZED SURFACE PRE-TREATMENT.  
POLYESTER POWDER COAT WITH UV STABILIZED COMPONENT.

AVAILABLE COLOR: SILVER / GREY.

## 應用位置

一般道路用燈 · 公園 · 停車地區 · 行人道 ·

## 結構

防腐蝕注鋁底殼。  
防腐蝕鋁型材柱。  
透明/奶白聚碳酸酯膠罩。  
銀色鋁百葉。  
防水密封條。  
連體電器。  
前處理電鍍表面。  
抗紫外光粉末噴塗。

外殼顏色：銀/灰。

## ORDER CODE 訂購編碼

Cat. No. 型號	Lamp 光源	
TVI-7301/7302/7303-70HSE	1x70w HSE	高壓鈉氣 E27
TVI-7301/7302/7303-100/150/250HSE	1x100w/150w/250w HSE	高壓鈉氣 E40
TVI-7301/7302/7303-80/125HME	1x80w/125w HME	高壓水銀 E27
TVI-7301/7302/7303-250 HME	1x250w HME	高壓水銀 E40
TVI-7301/7302/7303-70/100/150HIE	1x70w/100w/150w HIE	高壓金鹵 E27
TVI-7301/7302/7303-250HIE	1x250w HIE	高壓金鹵 E40